

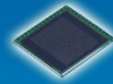

PSD030K 0.3MP Product Brief



The PSD030K shows low power consumption (less than 100mW) performance with global shutter and max. 240 fps.

The PSD030K is a 1/7.5-inch global shutter CMOS image sensor. It outputs black and white image with an effective pixel array of 644 (width) x 484 (height). The PSD030K can generate a 10-bit data at maximum frame rate of 240 fps through MIPI serial interface. On-chip sensor functions can be controlled through I2C interface

The output interface of PSD030K is 1/2-Lane MIPI , DVP Combo. It supports External synchronization (Genlock), Trigger mode. It is built in Strobe/PWM controller, one-time programmable (OTP) memory for part identification

Applications

- Barcode scanning
- Machine Vision
- VR
- Drones
- OCR
- IoT

Product Features

- 644x484 effective pixel array with BW and micro-lens
- Shutter type : Global shutter
- Advanced Performance 3.0um Pixel
- Output Interface : 1/2-Lane MIPI / DVP Combo
- Built-in one-time programmable (OTP) memory for part identification
- External synchronization(Genlock) support
- Built-in Strobe/PWM controller
- Low Power Consumption <100mW

Technical Specifications

Parameter	Typical value
Pixel size	3.0 um x 3.0 um
Effective pixel array	644(H) x 484(V)
Effective image area	1.932 mm x 1.452 mm
Optical format	1/7.5 inch
Input clock frequency	27 MHz
Output interface	1/2-Lane MIPI / DVP Combo (DVP@240fps) (2-lane MIPI@240fps@432/540Mbps) (1-lane MIPI@120fps@432/540Mbps)
Max. frame rate	240 fps (25/30/50/60/100/120/240 fps mode)
Dark signal	TBD e/sec
Sensitivity	TBD
Power supply	AVDD 2.8V, IO 1.8V only, DVDD 1.2V
Power consumption	100 mW
Operating temp. (Fully functional temp.)	TBD [°C]
Max. dynamic range	-
SNR	TBD [dB]
Chip size	3417 um x 2748 um, 32ball
Package type	CSP – MIPI 32pin CSP – DVP 32pin / COB

Functional Block Diagram

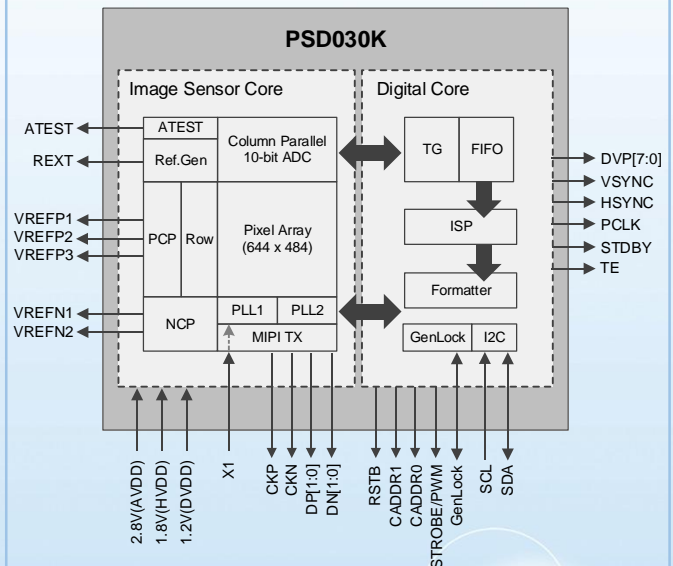



CSP Ball Map

Chip size : 3417 um x 2748 um, 32 ball

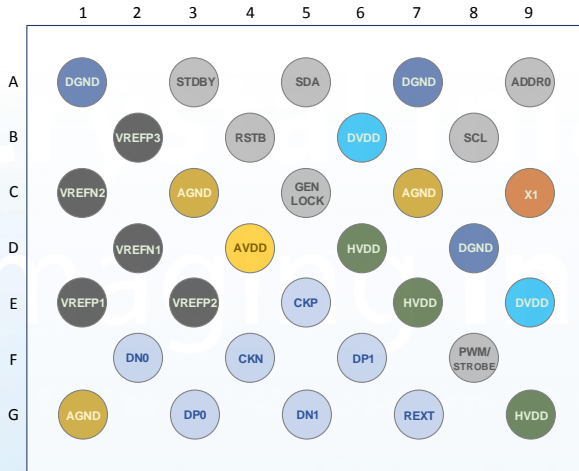

Package Top View For MIPI

- Analog Power Supply 2.8V
- Digital Power Supply 1.2V
- IO Power Supply 1.8V
- Clock
- Analog GND
- Digital GND
- MIPI TX output

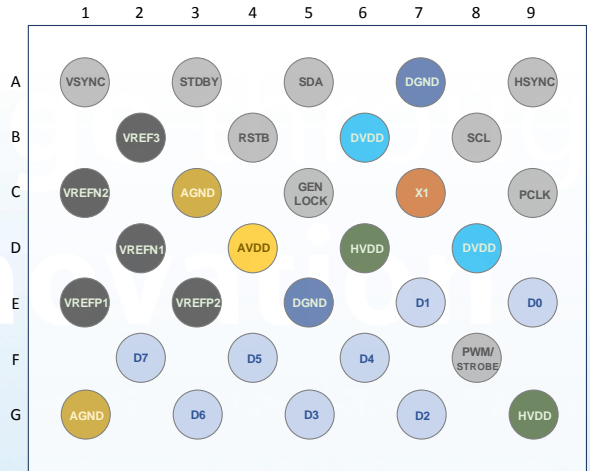

Package Top View For DVP

- Analog Power Supply 2.8V
- Digital Power Supply 1.2V
- IO Power Supply 1.8V
- Clock
- Analog GND
- Digital GND
- MIPI TX output

CSP Ball Description

CSP-MIPI Ball Description

Ball	Ball Name	IO	Pull up/ Pull down	Ball Description
A1	DGND	P	-	Digital ground
A3	STDBY	I	pulldown	Power standby mode
A5	SDA	BIO	pullup	2-wire serial interface data
A7	DGND	P	-	Digital ground
A9	ADDR0	I	pullup	Chip address selection bit
B2	VREFF3	O	-	PCP output
B4	RSTB	I	pullup	Reset (active low)
B6	DVDD	P	-	Digital 1.2V power
B8	SCL	BIO	pullup	2-wire serial interface clock
C1	VREFN2	O	-	NCP output
C3	AGND	P	-	Analog ground
C5	GENLOCK	BIO	pulldown	Frame sync input
C7	AGND	P	-	Analog ground
C9	X1	I	-	Master clock input pad
D2	VREFN1	O	-	NCP output
D4	AVDD	P	-	Analog 3.3V power
D6	HVDD	P	-	IO 1.8V power
D8	DGND	P	-	Digital ground
E1	VREFF1	O	-	PCP output
E3	VREFF2	O	-	PCP output
E5	CKP	O	-	MIPI clock positive output
E7	HVDD	P	-	IO 1.8V power
E9	DVDD	P	-	Digital 1.2V power
F2	DN0	O	-	MIPI data0 negative output
F4	CKN	O	-	MIPI clock negative output
F6	DP1	O	-	MIPI data1 positive output
F8	PWM	O	pulldown	Strobe or PWM output
G1	AGND	P	-	Analog ground
G3	DP0	O	-	MIPI data0 positive output
G5	DN1	O	-	MIPI data1 negative output
G7	REXT	O	-	External Resistor for bias
G9	HVDD	P	-	IO 1.8V power

CSP-DVP Ball Description

Ball	Ball Name	IO	Pull up/ Pull down	Ball Description
A1	VSYNC	BIO	pullup	Vertical SYNC.
A3	STDBY	I	pulldown	Power standby mode
A5	SDA	BIO	pullup	2-wire serial interface data
A7	DGND	P	-	Digital ground
A9	HSYNC	BIO	pullup	Horizontal SYNC.
B2	VREFF3	O	-	PCP output
B4	RSTB	I	pullup	Reset (active low)
B6	DVDD	P	-	Digital 1.2V power
B8	SCL	BIO	pullup	2-wire serial interface clock
C1	VREFN2	O	-	NCP output
C3	AGND	P	-	Analog ground
C5	GENLOCK	BIO	pulldown	Frame sync input
C7	X1	I	-	Master clock input pad
C9	PCLK	O	pullup	Pixel clock data
D2	VREFN1	O	-	NCP output
D4	AVDD	P	-	Analog 3.3V power
D6	HVDD	P	-	IO 1.8V power
D8	DVDD	P	-	Digital 1.2V power
E1	VREFF1	O	-	PCP output
E3	VREFF2	O	-	PCP output
E5	DGND	P	-	Digital ground
E7	D1	O	pulldown	Digital output bit 1
E9	D0	O	pulldown	Digital output bit 0
F2	D7	O	pulldown	Digital output bit 7
F4	D5	O	pulldown	Digital output bit 5
F6	D4	O	pulldown	Digital output bit 4
F8	PWM	O	pulldown	Strobe or PWM output
G1	AGND	P	-	Analog ground
G3	D6	O	pulldown	Digital output bit 6
G5	D3	O	pulldown	Digital output bit 3
G7	D2	O	pulldown	Digital output bit 2
G9	HVDD	P	-	IO 1.8V power